

UP Series Pneumatic Ball Vibrators Dims

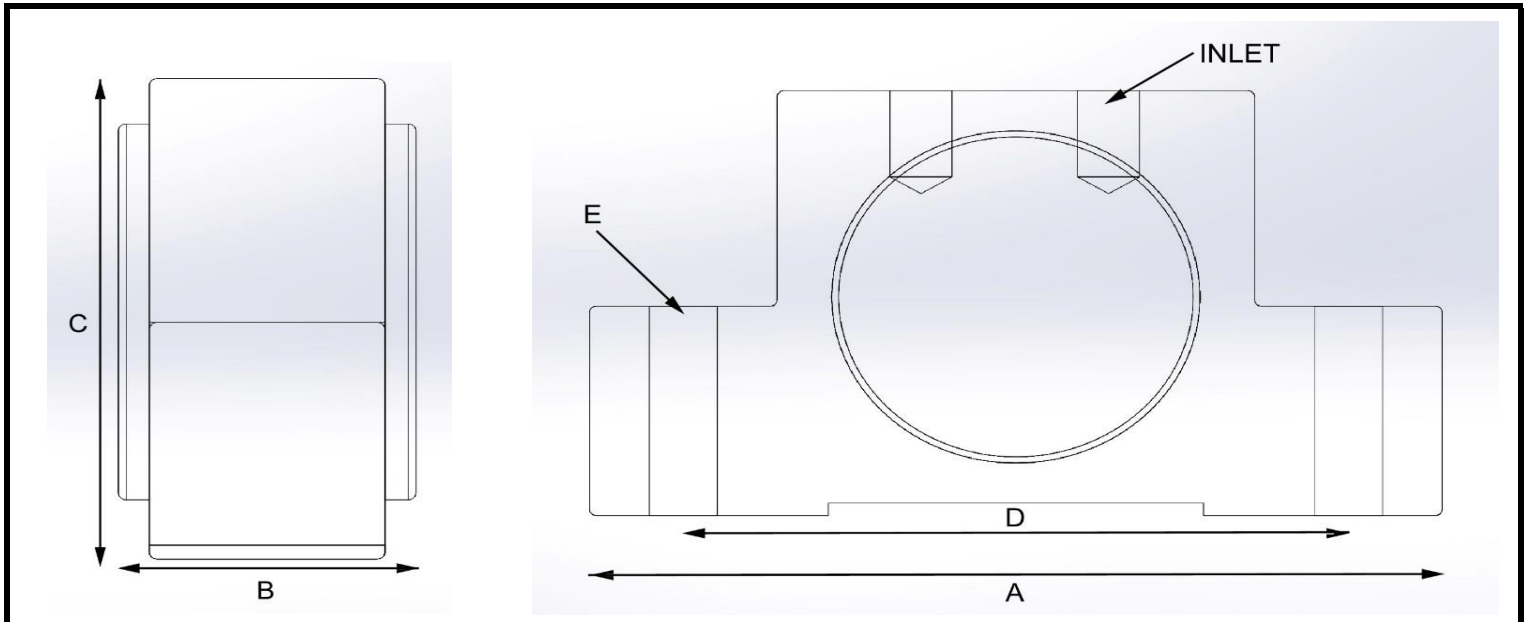

Model	UP-110	UP-113	UP-216	UP-219	UP-325	UP-335	UP-438	UP-441	UP-444	UP-451
Dim's in INCH / Weight LBS										
A	5"	5"	5 5/8"	5 5/8"	6 1/2"	6 1/2"	9"	9"	9"	9"
B	1 7/16"	1 7/16"	1 3/4"	1 3/4"	2 9/32"	2 9/32"	2 1/2"	2 1/2"	2 1/2"	2 1/2"
C	2 5/8"	2 5/8"	3 1/2"	3 1/2"	4"	4"	5 7/8"	5 7/8"	5 7/8"	5 7/8"
D	4"	4"	4 5/8"	4 5/8"	5 1/4"	5 1/4"	7 1/2"	7 1/2"	7 1/2"	7 1/2"
E	3/8"	3/8"	1/2"	1/2"	1/2"	1/2"	11/16"	11/16"	11/16"	11/16"
Inlet	1/8"NPT	1/8"NPT	1/4"NPT	1/4"NPT	1/4"NPT	1/4"NPT	1/2"NPT	1/2"NPT	1/2"NPT	1/2"NPT
Weight	0.5	0.5	1	1	2.5	2.5	5	6	6	6.5
P.N.	082180100	082180130	082180160	082180190	082180250	082180350	082180380	082180410	082180440	082180510



The UP series ball vibrators are ideal for many different types of industrial applications. The inovative design using high molecular composite material is ideal for sterile and food applications.